



FRONTGRADE

APPLICATION NOTE

XVR1553-AN-01

Effects of Transformer Construction in a
MIL-STD-1553 System

7/17/2012

Version #: 1.0.0

Table 1: Cross Reference of Applicable Products

Product Name:	Manufacturer Part Number	SMD #	Device Type	Internal PIC* Number:
SμMMIT DXE SμMMIT LXE	UT69151-DXE UT69151-LXE	5962-94663	08, 10, 11	MM026, MM023 MM025, MM027
SμMMIT XTE	UT69151-XTE	5962-94758	08	MM019
UT63M147 Bus Transceiver	UT63M147	5962-93226	03, 04	JB01, JB03
UT63M143 Bus Transceiver	UT63M143	5962-07242	01	JB04, JB05
UT63M1X5C Bus Transceiver	UT63M1X5C	N/A	N/A	BA02

* PIC = Product Identification Code

1. Overview

A MIL-STD-1553 terminal consists of a transceiver and either one or two transformers depending upon whether the terminal is configured for direct- or transformer-coupled mode of operation. Figure 1 shows a transformer-coupled terminal with an isolation transformer and coupling transformer. Transformer construction is an important factor to achieving optimal signal performance on the MIL-STD-1553 databus. Transformer characteristics have a direct relationship to the amplitude and degree of signal distortion. This application note discusses the importance of selecting transformers for proper signal integrity and reliability.

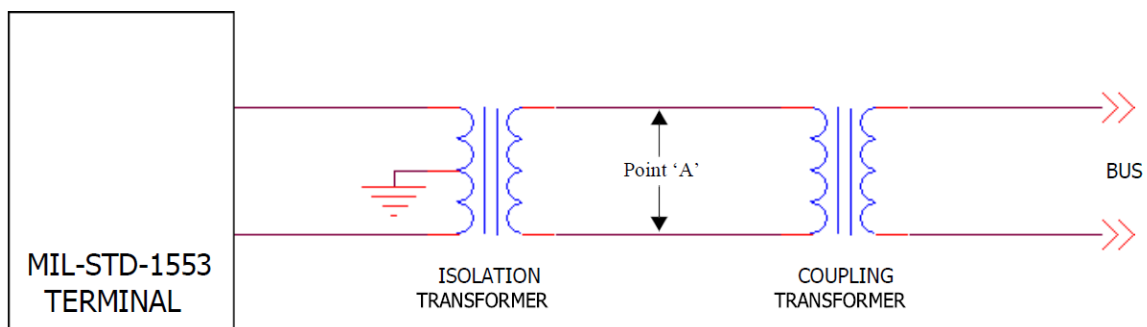

Figure 1. Typical MIL-STD-1553 Terminal

2. Transformer Construction

A high-quality MIL-STD-1553 transformer should have the following characteristics:

- Low inter-winding capacitance
- High coupling coefficient k
- Primary and secondary inductors wound together

Winding the primary and secondary inductors separately simplifies manufacturing but at the expense of asymmetry of the primary windings and higher leakage inductance. Asymmetry in the windings can result in signal distortion and in poor common-mode noise rejection. A lower coupling coefficient contributes to higher leakage inductance. Both asymmetry and leakage inductance generate unwanted signal excursions that can reduce transceiver operational life expectations.

The inter-winding capacitance and leakage inductance determine the frequency response of the transformer. The leakage inductance is also a significant factor to signal integrity and the resulting effects on system reliability. The coupling coefficient, k , ranges from 0 to 1 and is a measure of the coupling of the magnetic flux lines from the primary winding to the secondary winding. An ideal transformer will have $k = 1$.

Figure 2 shows a closed-core ferrite transformer, whose construction ensures that the magnetic flux lines are almost entirely contained within the ferrite core with minimal leakage flux. Closed-core transformers typically have a high k factor. In the case of a center-tapped primary, the closed-core ferrite transformer typically exhibits better symmetry between the two primary windings than is otherwise accomplished with different transformer constructions.

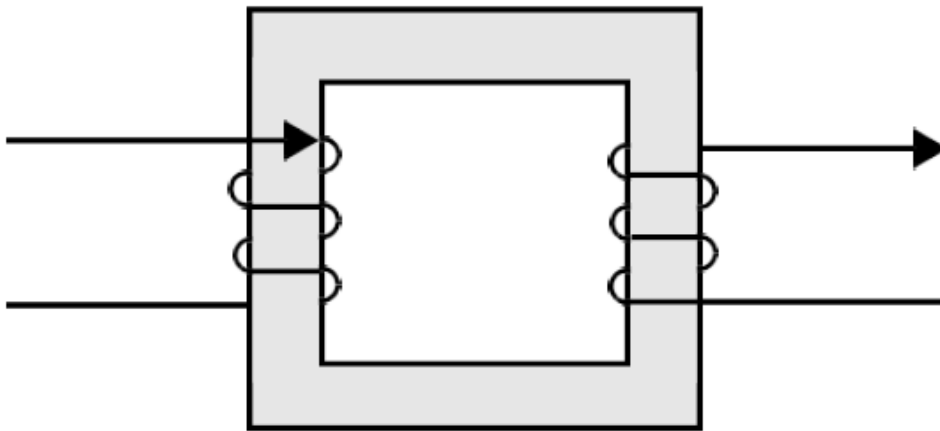

Figure 2. Closed-core Transformer

Figure 3 shows an open-core transformer. This type of construction generally results in lower coupling of the magnetic flux lines between the primary and secondary windings. The resultant leakage flux does not result in power loss as the energy is stored in a magnetic field. However, the leakage flux appears as an inductor in series with the primary and secondary windings.

This parasitic inductor caused by the leakage flux is referred to as the leakage inductance. The primary and secondary windings of open-core transformers are often wound separately e.g. the primary is wound first and the secondary is wound over the primary winding. This results in lower inter-winding capacitance but higher leakage inductance.

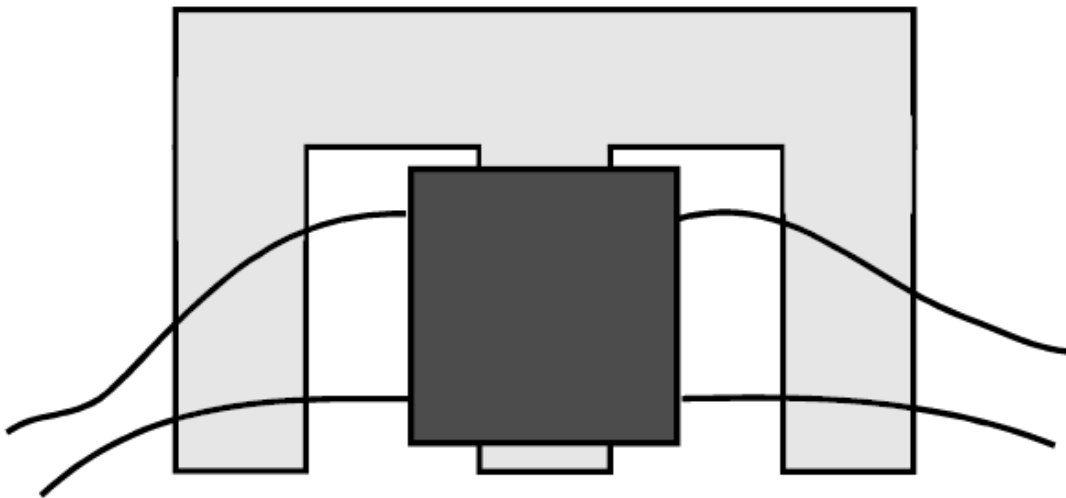

Figure 3. Open-core Transformer

Another potential problem with open core transformers is the resultant asymmetry between the two primary windings. Consider the schematic representation of a MIL-STD-1553 isolation transformer shown in Figure 4. Ideally, $L_{p1} = L_{p2}$. In a transformer whose primary windings are imbalanced (i.e. $L_{p1} \neq L_{p2}$), unwanted signal distortion can occur.

The MIL-STD-1533 standard places tight restrictions on signal characteristics, such as amplitude, rise/fall time, and zero-cross distortion. A transceiver is designed to produce a signal that meets all of these requirements. However, when an imbalance exists between the two primary windings, the transceiver will attempt to compensate for the imbalance, resulting in signal waveforms that exhibit excessive undershoot or distortion.

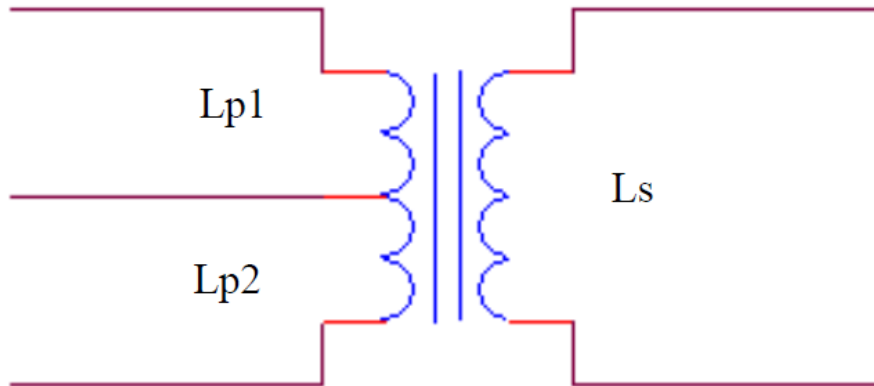

Figure 4. Transformer with Center-Tapped Primary Winding

3. Modeling Leakage Inductance

Figure 5 shows a circuit representation of a transformer with leakage inductance. The primary and secondary windings have an inductance of L_1 and L_2 , respectively. Due to leakage flux, k is less than 1 resulting in leakage inductances l_1 and l_2 .

$$l_1 = (1-k) \cdot L_1$$

$$l_2 = (1-k) \cdot L_2$$

The ideal transformer represents the non-lossy portion of the transformer having perfect magnetic flux coupling between the primary and secondary windings. Ideal transformers have a transfer function equal to $(L_2/L_1)^{1/2}$ as shown in Figure 4.

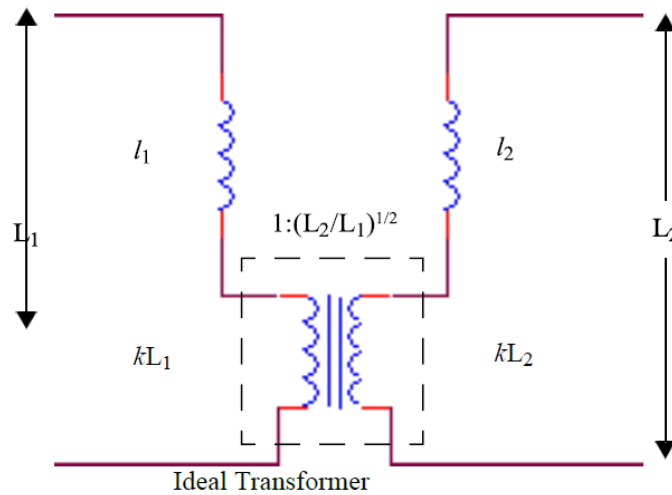

Figure 5. Circuit Representation of Transformer with Leakage Inductance

If we assume that $kL_1, kL_2 \gg l_1, l_2$, then it follows that the total leakage inductance seen at the primary side of the transformer is approximately:

$$l_1 + l_2 \cdot (L_1/L_2)$$

The simplified first-order circuit model is shown in Figure 6. The final model has a primary and secondary inductance kL_1 and kL_2 , a turns ratio of $1:(L_2/L_1)^{1/2}$, and leakage inductance $l_1 + l_2 \cdot (L_1/L_2)$. The primary side center tap is not shown here.

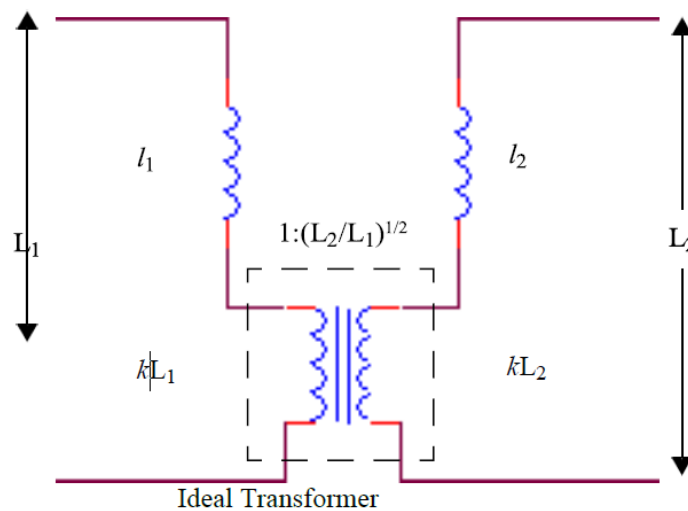

Figure 6. Simplified Model of Transformer with Leakage Inductance

4. Asymmetry and Leakage Inductance Effects upon Signal Integrity

The waveform shown in Figure 7 illustrates the typical signals in a system utilizing a MIL-STD-1553 isolation transformer that has both asymmetry and high leakage inductance. The simulation model of the transformer includes the parasitic elements and leakage inductance as shown in Figure 6. The green and red traces are the signals directly at the output pins of the transceiver and show the undershoot that results from the nonideal transformer characteristics. The blue trace is the voltage wave- form at point 'A', as indicated in Figure 1. Note that although there is no discernible over- and undershoot in the signal at point 'A', there is considerable undershoot in the voltage levels of the transceiver outputs. This undershoot could result in longterm reliability degradation to the transceiver if the amplitude exceeds the maximum rating of the device.

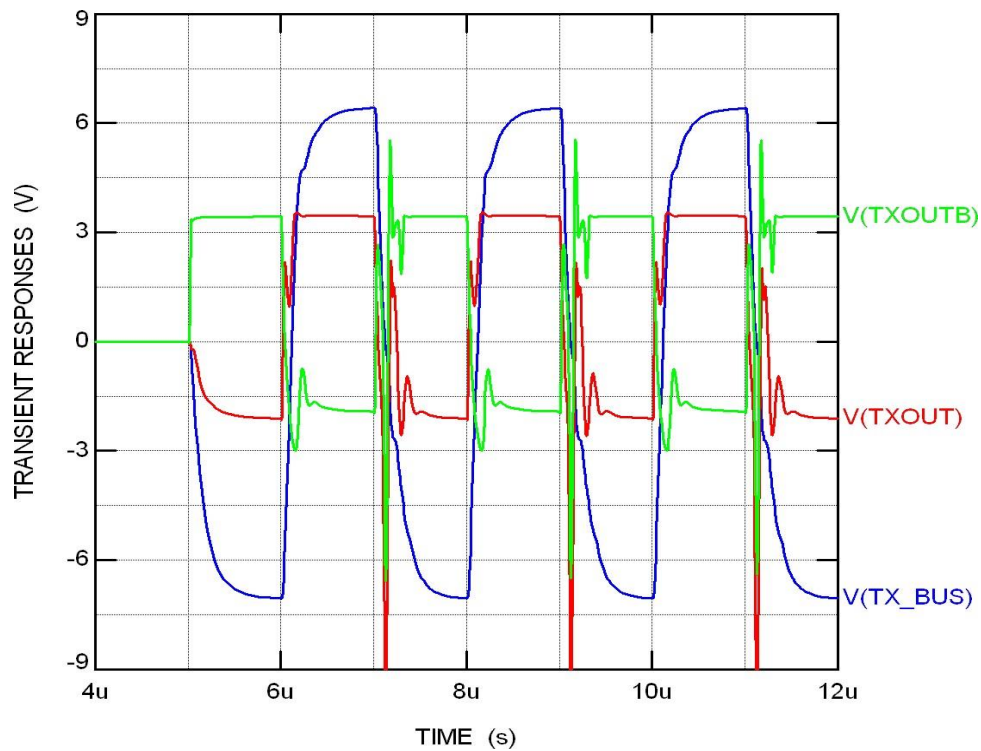

Figure 7. Transmitted Signal at Point 'A' in a MIL-STD-1553 System with Finite Leakage Inductance

5. Conclusion

The construction approach and quality of transformers should be a careful consideration in any MIL-STD1553 system. System designers should select high-quality transformers with good symmetry and low leakage inductance in order to meet the ac and dc requirements of the components in the system. Selecting transformers whose primary and secondary are wound together on a closed core produces better magnetic coupling and symmetry than one whose primary and secondary are wound separately or on an open core. Failure to select transformers with proper qualities can result in lower than expected system performance and limited mission life.

No transformer has ideal coupling between its constituent windings or perfectly balanced primary windings. Therefore, there will always be some finite amount of asymmetry and leakage inductance. Designers should verify their design by measuring the waveforms at the transceiver pins and at point 'A' of the MIL-STD-1553 databus to verify signal quality and compliance with the transceiver's electrical requirements and with respect to MIL-STD-1553 performance specifications.

6. References

North Hills Signal Processing Corporation. Application Note # 151 and # 254.

<http://www.northhills-sp.com>

Dixon, Lloyd H. Jr. The Effects of Leakage Inductance on Switching Power Supply Performance.

<http://www.ti.com/lit/ml/slup199/slup199.pdf>

Revision History

Date	Revision #	Author	Change Description	Page #

Frontgrade Technologies Proprietary Information Frontgrade Technologies (Frontgrade or Company) reserves the right to make changes to any products and services described herein at any time without notice. Consult a Frontgrade sales representative to verify that the information contained herein is current before using the product described herein. Frontgrade does not assume any responsibility or liability arising out of the application or use of any product or service described herein, except as expressly agreed to in writing by the Company; nor does the purchase, lease, or use of a product or service convey a license to any patents rights, copyrights, trademark rights, or any other intellectual property rights of the Company or any third party.